

REVISION HISTORY				
REV	DATE	DESCRIPTION	ECO	BY
A	8/16/2012	PRODUCTION RELEASE	13629	SV

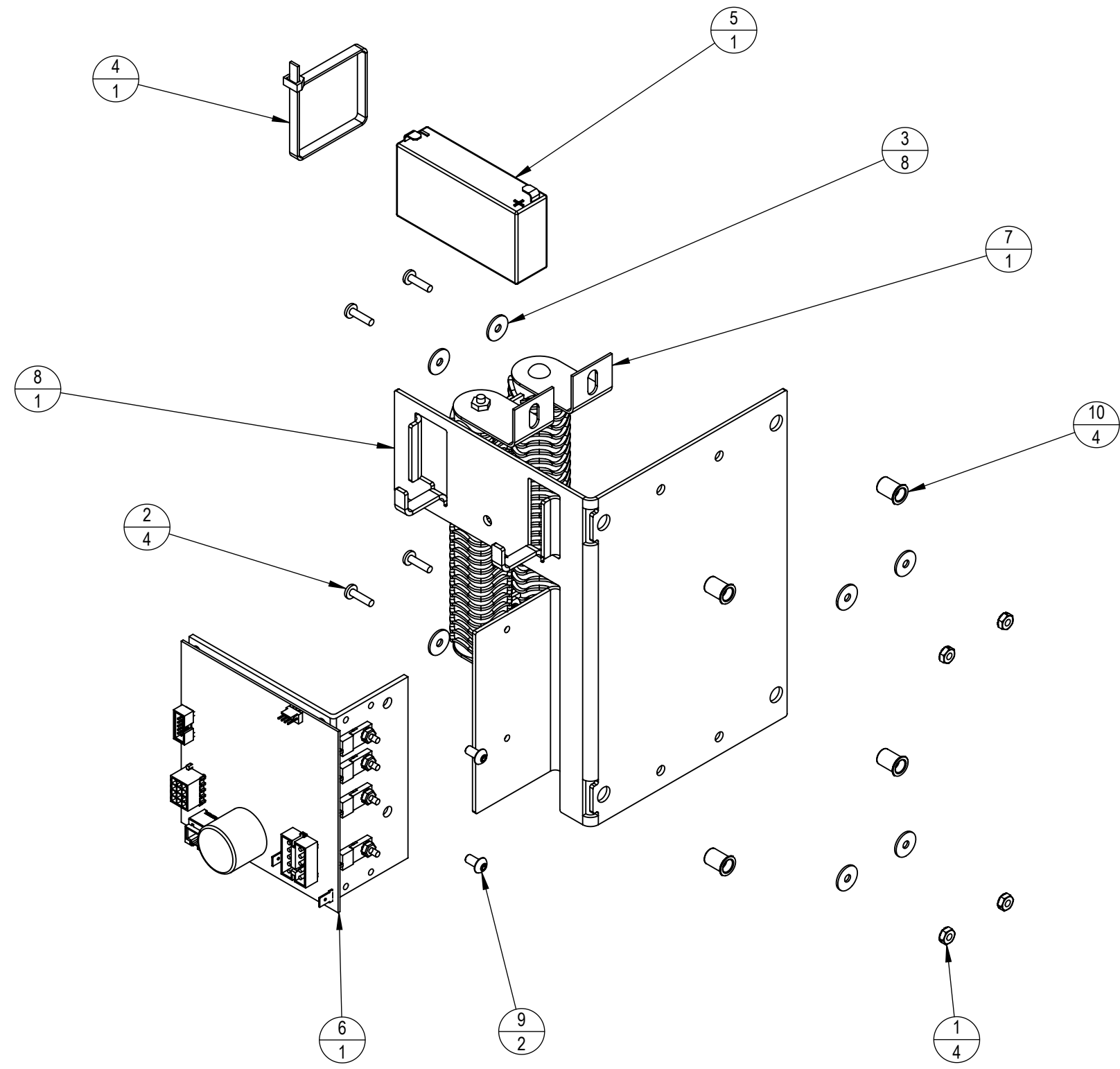

ITEM NO.	PART NUMBER	DESCRIPTION	QTY.
1	110-1750	NUT, #8-32, KEP	4
2	110-3095	SCREW, #8-32 X .625, PHMS	4
3	120-3295	WASHER, #8, 0.625\"OD, ZP	8
4	140-0220	TIE STRAP, 14"	1
5	580-0275	BATTERY, 6V NP	1
6	711-3162	ASSY, LCB, STEPPER	1
7	711-3242	LOAD RESISTORS, LCB, STEPMILL/STEPPER	1
8	711-3324	PLATE, LCB MOUNTING, STEPMILL	1
9	740-7182	SCREW, M5X0.8X10, BHC, HE, SS	2
10	740-7304	NUT, RIVET, M6	4

DOCUMENT STATUS:

NOTICE OF PROPRIETARY INFORMATION
 THIS DOCUMENT SHALL NOT BE REPRODUCED NOR SHALL THE INFORMATION CONTAINED HEREIN BE USED BY OR DISCLOSED TO OTHER EXCEPT AS EXPRESSLY AUTHORIZED BY CORE INDUSTRIES, INC., D.B.A. STAR TRAC.

CLASS OF WORK	UNLESS OTHERWISE SPECIFIED DIMS ARE IN mm. TOLERANCES FOR MEASURE OF LENGTH ARE:							ANGLES = ±2°
	0.5 to 3	>3 to 6	>6 to 30	>30 to 120	>120 to 400	>400 to 1000	>1000 to 2000	
FINE	±0.05	±0.05	±0.1	±0.15	±0.2	±0.3	±0.5	----
MEDIUM	±0.1	±0.1	±0.2	±0.3	±0.5	±0.8	±1.2	±2
COARSE	±0.2	±0.3	±0.5	±0.8	±1.2	±2	±3	±4
VERY COARSE	----	±0.5	±1	±1.5	±2.5	±4	±6	±8

MATERIAL
SEE BOM

FINISH
N/A

VENDOR: LAND AMERICA P/N:

THIRD ANGLE PROJECTION		
DRAWN	INITIAL SV	DATE 08/16/2012
CHECKED		
APPROVED		

CORE INDUSTRIES, INC. DBA
STAR TRAC
 14410 Myford Road
 Irvine CA 92606

STARTRAC PART NO
711-3325

TITLE
ELEC PLATE ASSY, STARMILL

SCALE: 1:3 SHEET 1 OF 1 SHEET SIZE: B